

For your safety, please read the following before using.

- Check the regulator and flow adjustment valve before introducing the fluid.**
If the pressure or flow rate exceeded the specified range, the sensing element may be damaged.
- The sensing element cannot measure properly if foreign matter adheres to it.**
- On the inlet side, be sure to install an air filter below the filtration level of 10um.**
- Recommended Equipments and Installation**

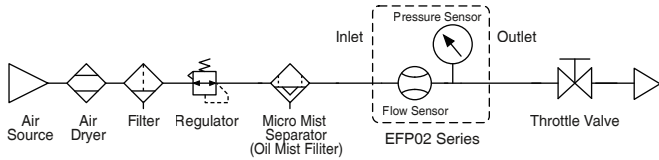

※ NOTE :
Please install a throttle valve on the outlet side of the sensor to prevent errors caused by unstable flow.

- Use straight piping 8cm or longer to connect the Piping Port (Inlet side).**

If straight piping is not installed, the accuracy may vary by $\pm 2\%$ F.S..
Avoid sudden changes in the piping size on the inlet side of the product.
Do not release the outlet side piping port of the product directly to the atmosphere without the piping connected.

(※ Straight Piping : The pipe is without bending and the cross sectional areas of the pipe keeps the same.)

- When piping, please apply I.D. 9 mm or more air tube.**
- Please use a wrench on the metallic area and torque properly.**

When piping with metallic area, please refer to the applicable torque below.
Over torquing may be damaged the product. When insufficient torque, the connection may loosen to cause air leakage.

After installation completed, please make gas and power on and operate properly and test leakage to verify the installation correct.

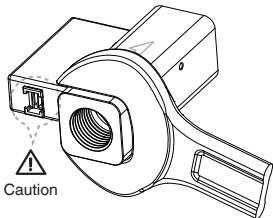

Piping Specification	Required Torque
Rc $\frac{1}{2}$ " , G $\frac{1}{2}$ "	28~30 Nm
Rc $\frac{3}{4}$ " , G $\frac{3}{4}$ "	

A. ORDERING INFORMATION

EFP02 - 501 - 010 - F7C

Flow Rate Range

501: 500 L/min
102: 1000 L/min
202: 2000 L/min

Output Specifications

010 : 2 NPN output + Analog output 1~5V
011 : 2 NPN output + Analog output 4~20mA
02 : 2 NPN output + RS485
030 : 2 PNP output + Analog output 1~5V
031 : 2 PNP output + Analog output 4~20mA
04 : 2 PNP output + RS485

Port Size

F7C : Rc $\frac{1}{2}$ " , for Flow Rate Range 501, 102.
F9C : G $\frac{1}{2}$ " , for Flow Rate Range 501, 102.
F10C : Rc $\frac{3}{4}$ " , for Flow Rate Range 202.
F12C : G $\frac{3}{4}$ " , for Flow Rate Range 202.

Optional Parts

BT-27 : Mounting bracket, for Flow Rate Range 501, 102.
BT-28 : Mounting bracket, for Flow Rate Range 202.

B. PANEL DESCRIPTION

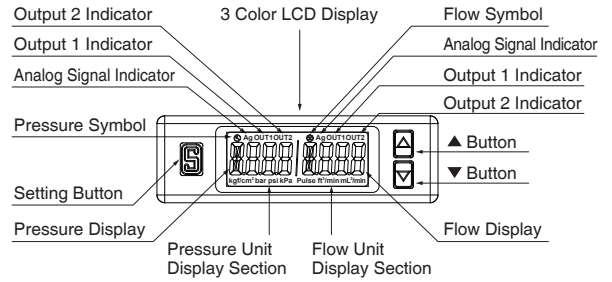

C. OUTPUT CIRCUIT WIRING DIAGRAMS

EFP02-□-010 NPN Output / Analog Voltage Output / External Input

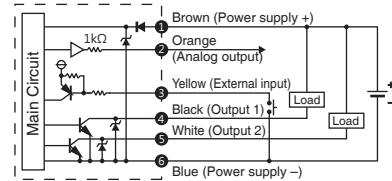

EFP02-□-011 NPN Output / Analog Current Output / External Input

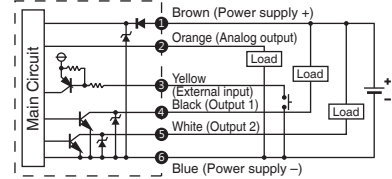

EFP02-□-030 PNP Output / Analog Voltage Output / External Input

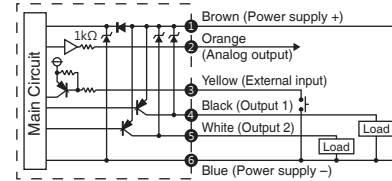

EFP02-□-031 PNP Output / Analog Current Output / External Input

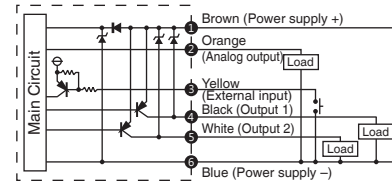

EFP02-□-02 NPN Output, RS-485 Modbus

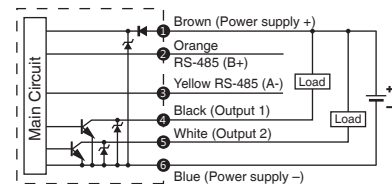



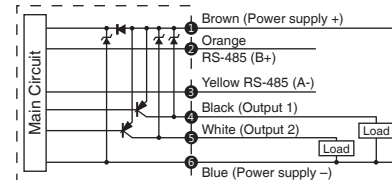

EFP02-□-04 PNP Output, RS-485 Modbus



D. OPERATION INSTRUCTIONS

1. Function Selection Mode

At Measurement Mode, press  button for more than 3 sec. to display [F-0] i. Press  or  button to select other setting functions. Press  for 3 sec. at Function Setting Mode to return to Measurement Mode.

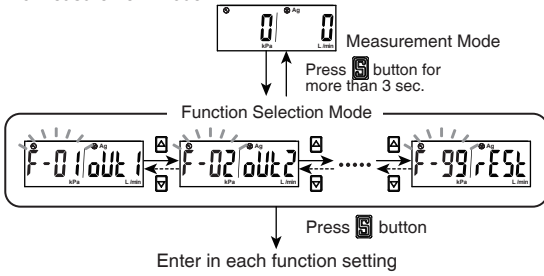

2. [F-0] i OUT1 Setting Selection

1. Flow sensor setting

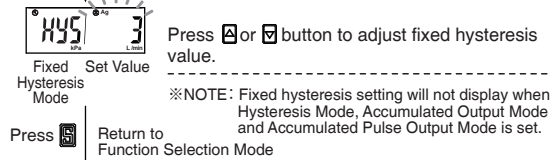
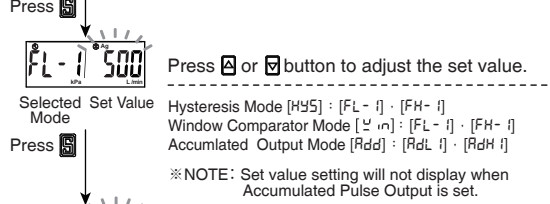
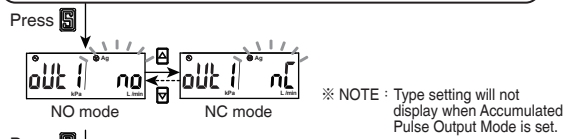
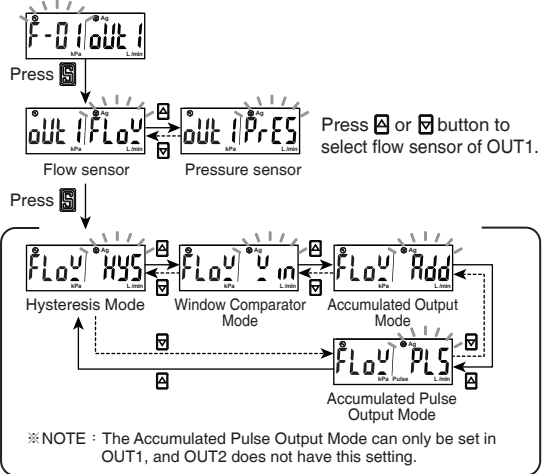

2. Pressure sensor setting

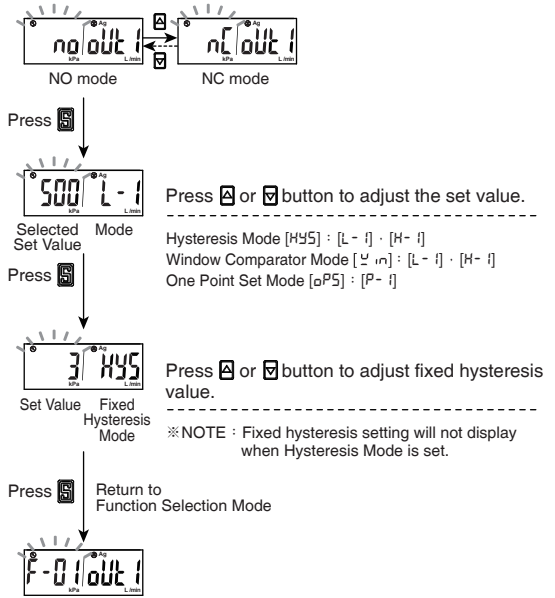
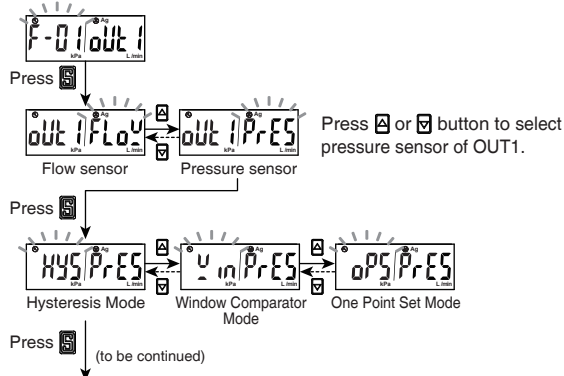

Normal Open Mode

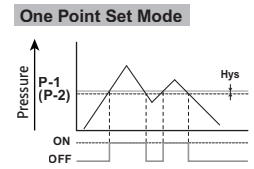
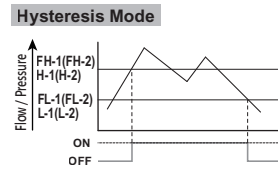

Window Comparator Mode

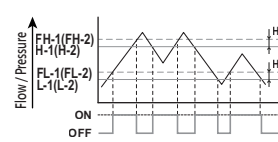

Accumulated Output Mode

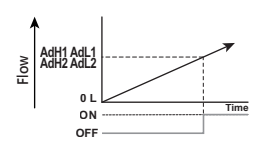

Accumulated Pulse Output Mode

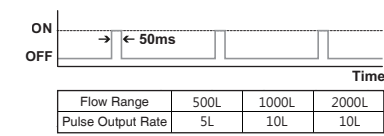

NOTE:

- In case hysteresis is set at less than or equal to 2 digits, switch output may chatter if input pressure fluctuates near the set point.
- When using window comparator mode, the difference between two set points must be greater than the fixed hysteresis, otherwise will cause the switch output to malfunction.

3. [F-02] OUT2 Setting Selection

Check the [F-0] i for the same follow setting.

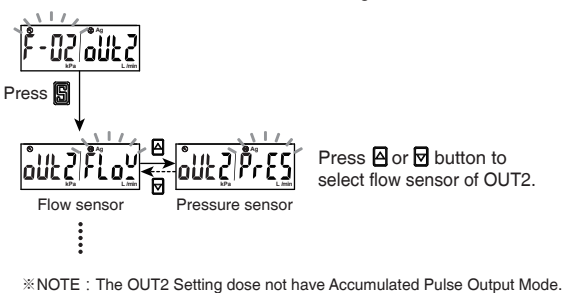

D. OPERATION INSTRUCTIONS

4 [F-07] Flow Reference Standard Selection

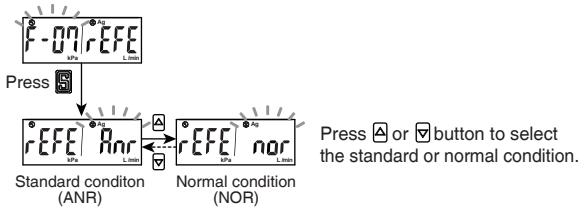

※ NOTE :

1. Standard condition (ANR): the display value is calculated under 20°C, 1atm.
2. Normal condition (NOR): the display value is calculated under 0°C, 1atm.
3. Flow rate in the specification is the value at standard condition (ANR).

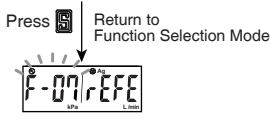

5 [F-08] Analog Output Selection

※ This function is not available with Output Specification -02 and -04.

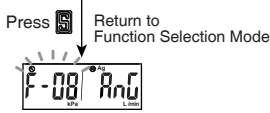
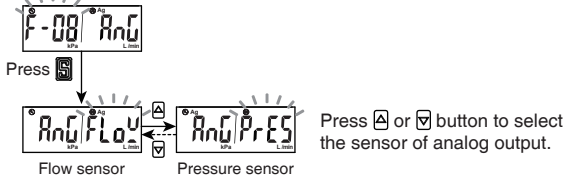

6 [F-10] Flow Sensor Display Mode Selection

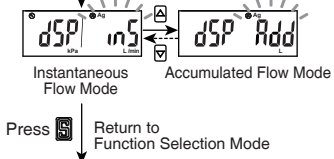
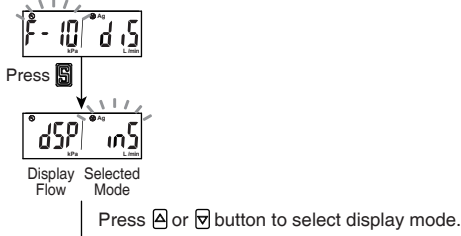

7 [F-80] Sync the value of flow analog output and display

※ 1. This function is not available with Output Specification -02 and -04.
 2. This function is available for output of flow rate only.

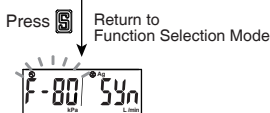
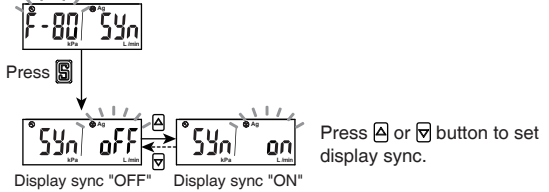

8 [F-93] Modbus RTU Setting

※ This function only available for Output Specification -02 and -04.

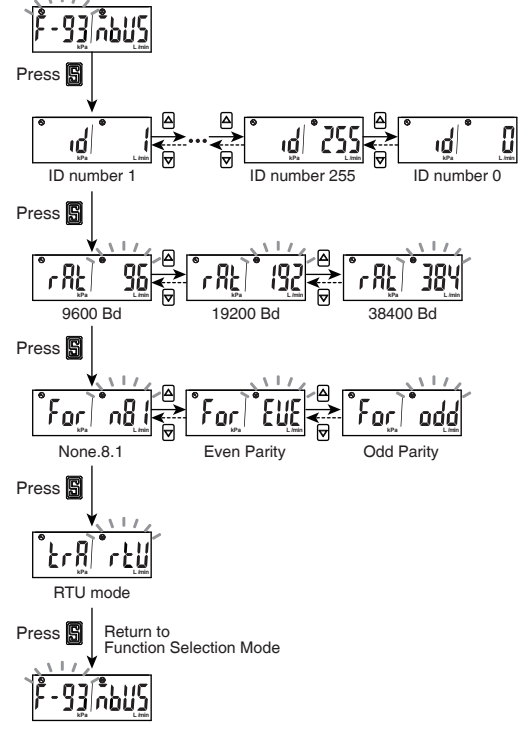

9 Pressure Zero Adjustment Function

The displayed value can be adjusted to "0" when the pressure is within ±3% F.S. of the zero point at the time of shipment from the factory.

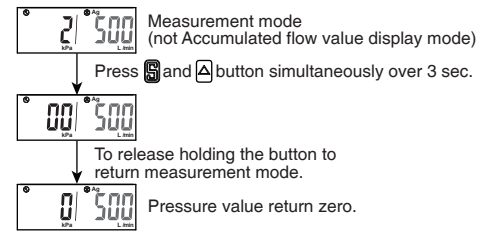

10 Instantaneous Flow Zero Adjustment Function

The displayed value can be adjusted to "0" when the measured flow is within ±5% F.S. of the zero point at the time of shipment from the factory.

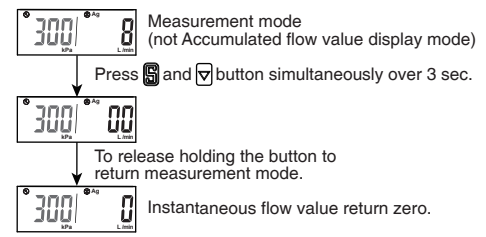

11 Reset Accumulated Flow Function

Measurement mode (Accumulated flow value mode)

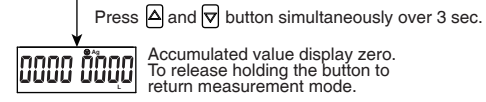

12 Key Lock / Unlock Mode

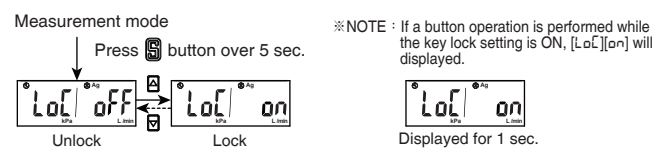

E. Modbus RTU INSTRUCTIONS

Function Code	Explanation	Operation	Function Code	Explanation	Operation	Function Code	Explanation	Operation
0000H	ID Number (0 ~ 255) Range : 0 ~ 255	Read Write	0014H	Fine adjustment of display value -25 ~ 25 (-2.5% ~ +2.5%)	Read Write	002AH	Fixed hysteresis setting for flow value HYS 0 ~ 8	Read Write
0001H	Baud rate setting 0 : 9600 bps 1 : 19200 bps 2 : 38400 bps	Read Write	0015H	Response time of flow sensor 0 : 50ms 1 : 80ms 2 : 120ms 3 : 200ms 4 : 400ms 5 : 800ms 6 : 1500ms	Read Write	002BH	Pressure setting value P-2 or L-2	Read Write
0002H	Transmission format setting 0 : N.8.1 1 : E.8.1 2 : O.8.1	Read Write	0016H	Response time of pressure sensor 0 : 2.5ms 1 : 25ms 2 : 100ms 3 : 250ms 4 : 500ms 5 : 1000ms 6 : 1500ms	Read Write	002CH	Pressure setting value H-2	Read Write
0003H	Communications protocol setting 0 : RTU	Read Write	0017H	OUT1 corresponding sensor 0 : FLOW SENSOR 1 : PRESSURE SENSOR	Read Write	002DH	Fixed hysteresis setting for pressure value HYS 0 ~ 8	Read Write
0004H	Measured flow rate range 7 : 500 L/min 8 : 1000 L/min 9 : 2000 L/min	Read	0018H	OUT1 output mode FLOW PRESSURE 0 : HYS 0 : OPS 1 : WIN 1 : HYS 2 : ADD 2 : WIN 3 : PLS	Read Write	002EH	OUT2 switch 0 : OFF 1 : ON	Read
0005H	Instantaneous flow value	Read	0019H	OUT1 output type 0 : N.O. mode 1 : N.C. mode	Read Write	002FH	Color display for OUT1 or OUT2 selection 0 : OUT1 1 : OUT2	Read Write
0006H	Flow unit 0 : LPM (L/min or mL/min) 1 : CFM (ft ³ /min)	Read Write	001AH	Flow setting value FL-1	Read Write	0030H	Display color setting 0 : SOG (Switch on Green) 1 : SOR (Switch on Red) 2 : GRN (Always is Green) 3 : RED (Always is Red)	Read Write
0007H	Decimal place for flow value 0 : None 1 : One decimal place 0.1 2 : Two decimal places 0.01 3 : Three decimal places 0.001	Read	001BH	Flow setting value FH-1	Read Write	0031H	Power-save mode 0 : NO 1 : YES	Read Write
0008H	Accumulated flow value (ADL) XXXX 9999	Read	001CH	Flow setting value ADL1	Read Write	0032H	Reset to the default setting 0 : RECALL	Write
0009H	Accumulated flow value (ADH) 9999 XXXX	Read	001DH	Flow setting value ADH1	Read Write	0033H	Instant flow zero adjustment 0 : When over ±5% F.S., error code 03H will show.	Write
000AH	Flow reference standard 0 : ANR (Standard condition) 1 : NOR (Normal condition)	Read Write	001EH	Fixed hysteresis setting for flow value HYS 0 ~ 8	Read Write	0034H	Pressure zero adjustment 0 : When over ±3% F.S., error code 03H will show.	Write
000BH	Flow sensor display mode 0 : Instantaneous flow 1 : Accumulated flow	Read Write	001FH	Pressure setting value P-1 or L-1	Read Write	0035H	Reset accumulated flow 0 : Accumulated flow value return to zero	Write
000CH	Accumulated value hold 0 : None 1 : 2min /times 2 : 5min/times	Read Write	0020H	Pressure setting value H-1	Read Write	0036H	Key lock/unlock setting 0 : OFF 1 : ON	Read Write
000DH	Flow display refresh time 0 : 200ms 1 : 500ms 2 : 1000ms	Read Write	0021H	Fixed hysteresis setting for pressure value HYS 0 ~ 8	Read Write	0037H	Switch output 0 : NPN 1 : PNP	Read
000EH	Rated pressure range 3 : -0.100 ~ 1.000 MPa	Read	0022H	OUT1 switch 0 : OFF 1 : ON	Read			
000FH	Display pressure value	Read	0023H	OUT2 corresponding sensor 0 : FLOW SENSOR 1 : PRESSURE SENSOR	Read Write			
0010H	Pressure unit 0 : kPa 1 : Kg/cm ² 2 : bar 3 : psi	Read Write	0024H	OUT2 output mode FLOW PRESSURE 0 : HYS 0 : OPS 1 : WIN 1 : HYS 2 : ADD 2 : WIN	Read Write			
0011H	Decimal place for pressure value 1 : One decimal place 0.1 2 : Two decimal places 0.01 3 : Three decimal places 0.001	Read	0025H	OUT2 output type 0 : N.O. mode 1 : N.C. mode	Read Write			
0012H	Pressure display refresh time 0 : 200ms 1 : 500ms 2 : 1000ms	Read Write	0026H	Flow setting value FL-2	Read Write			
0013H	Fine adjustment setting 0 : OFF 1 : FLOW SENSOR 2 : PRESSURE SENSOR	Read Write	0027H	Flow setting value FH-2	Read Write			
			0028H	Flow setting value ADL2	Read Write			
			0029H	Flow setting value ADH2	Read Write			









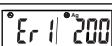

F. FUNCTION INSTRUCTION

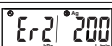
Function Code	Item	Explanation
[F - 01]	[OUT1] OUT 1 setting	Select Output 1 corresponding to flow sensor or pressure sensor. Set the flow rate or pressure value to switch ON/OFF.
[F - 02]	[OUT2] OUT 2 setting	Select Output 2 corresponding to flow sensor or pressure sensor. Set the flow rate or pressure value to switch ON/OFF.
[F - 03]	[LCD] LCD Display color selection	Select back light color and display mode.
[F - 04]	[RESP] Response time selection	Select the response time for analog output. Pressure sensor: 2.5ms ~ 1500ms. Flow sensor: 50ms ~ 1500ms.
[F - 05]	[DR] Display refresh time selection	Display refresh cycle can be set in 200ms, 500ms or 1000ms.
[F - 06]	[UNIT] Unit selection	Select the UNIT of pressure / flow sensor.
[F - 07]	[REF] Flow reference standard selection	Select the flow value is shown under standard (ANR) or normal condition (NOR).
[F - 08]	[ANL] Analog output selection	Select the analog corresponding to pressure or flow sensor. (*1)
[F - 09]	[EEP] Accumulated value hold selection	To save the last accumulated flow value every 2 or 5 minutes.
[F - 10]	[DIS] Flow sensor display mode selection	Select to display Instantaneous Flow or Accumulated Flow Mode.
[F - B0]	[SYN] Sync the value of flow analog output and display	Turn ON to synchronize the value of flow analog output and display. (*1) (*3) (Default setting : OFF)
[F - 91]	[ESC] Power-Save mode selection	Select if turn on power-save mode to reduce power consumption
[F - 92]	[INP] External input selection	Select for Accumulated flow rate zero clear, Auto-Shift or Auto-Shift zero. (*1)
[F - 93]	[MOD] Modbus RTU setting	Set ID number, baud rate and transmission format. (*2)
[F - 94]	[FINE] Fine adjustment setting	The displayed value can be adjusted slightly.
[F - 95]	[FOR] Forced output function	To force output ON/OFF to test the switch function.
[F - 99]	[RST] Reset to the default setting	Return to the factory default setting.

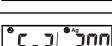
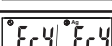
※ Note :

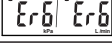
1. This function is not available with Output Specification -02 and -04.
2. This function only available for Output Specification -02 and -04.
3. This function is available for output of flow rate only.

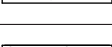
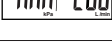
G. ERROR CODE INSTRUCTION

Error Type	Error Code	Error Condition	Troubleshooting
OUT1 Excess Load Current Error		Output 1 load current is more than 125 mA.	Turn power off and check the cause of overload current or lower the current load under 125 mA, then restart.
			
OUT2 Excess Load Current Error		Output 2 load current is more than 125 mA.	
			
Zero Adjustment Error		The instant flow is within ±5% F.S. of the zero point.	Perform the zero clear function again under no flow conditions.
		The pressure value is over ±3% F.S. of the zero point.	Perform the zero clear function again under no pressure conditions.
System Error		Memory error	Turn power off, and then restart. If error condition remains, please return to factory for inspection.
		Internal data error	
		Internal data error	
		System parameter error	
Applied Flow/ Pressure Error		The instant flow has exceeded the upper limit of the flow display range.	Reduce the flow to the display range.
		The pressure has exceeded the upper limit of the pressure display range.	Reduce the pressure to the display range.
		The instant flow has exceeded the lower limit of the flow display range.	Ensure the flow is in the correct direction.
		The pressure has exceeded the lower limit of the pressure display range.	Reduce the pressure to the display range.