

For your safety, please read the following before using.

- ① **Check the regulator and flow adjustment valve before introducing the fluid.**
If the pressure or flow rate exceeded the specified range, the sensing element may be damaged.
- ② **The sensing element cannot measure properly if foreign matter adheres to it.**
- ③ **On the inlet side, be sure to install an air filter below the filtration level of 10um.**
- ④ **Recommended Equipments and Installation**

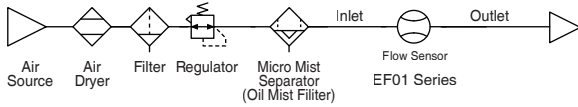

※ NOTE :
When measuring the pressure of the inlet side, install a throttle valve or solenoid valve on the outlet side.
When measuring the pressure of the outlet side, install a throttle valve or solenoid valve on the inlet side.

- ⑤ **Recommended Equipments and Installation Example**

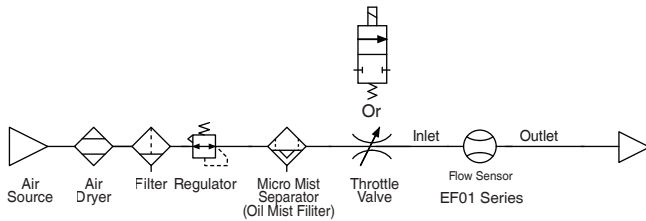

B. PANEL DESCRIPTION

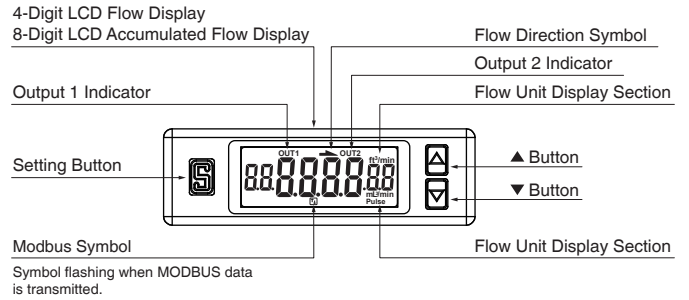

C. OUTPUT CIRCUIT WIRING DIAGRAMS

EF01-□-010 NPN Output / Analog Voltage Output / External Input

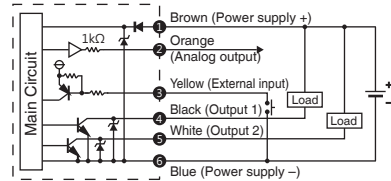

EF01-□-011 NPN Output / Analog Current Output / External Input

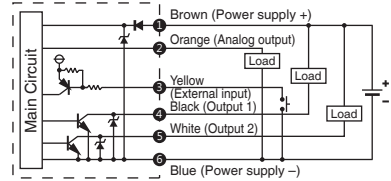

EF01-□-030 PNP Output / Analog Voltage Output / External Input

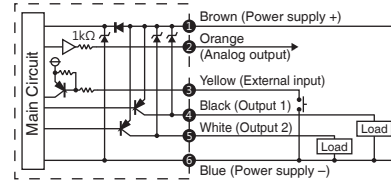

EF01-□-031 PNP Output / Analog Current Output / External Input

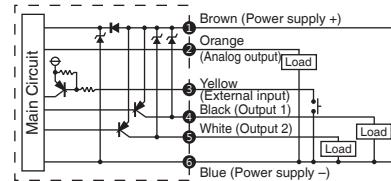

EF01-□-02 NPN Output, RS-485 Modbus

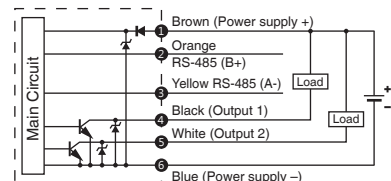

EF01-□-04 PNP Output, RS-485 Modbus

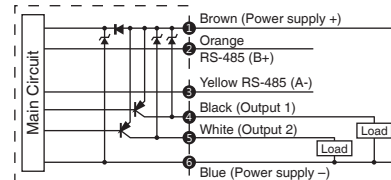

A. ORDERING INFORMATION

EF01 - 005 - 010 - R6

Flow Rate Range

005: 500 mL/min	500: 50 L/min
010: 1000 mL/min	101: 100 L/min
050: 5 L/min	201: 200 L/min
100: 10 L/min	

Output Specifications

010 : 2 NPN output + Analog output 1~5V
 011 : 2 NPN output + Analog output 4~20mA
 02 : 2 NPN output + RS485
 030 : 2 PNP output + Analog output 1~5V
 031 : 2 PNP output + Analog output 4~20mA
 04 : 2 PNP output + RS485

Port Size





R6 : $\varnothing 6$ mm, for Flow Rate Range 005, 010, 050, 100, 500.
 R8 : $\varnothing 8$ mm, for Flow Rate Range 101, 201.
 F1C : Rc $\frac{1}{8}$ ", with internal threads,
 for Flow Rate Range 005, 010, 050, 100, 500.
 F4C : Rc $\frac{1}{4}$ ", with internal threads, for Flow Rate Range 101, 201.

Optional Parts

BT-26 : Mounting bracket
 PA-G : Panel adapter
 PA-H : Panel adapter +Front protective lid

D. OPERATION INSTRUCTIONS

1 Function Selection Mode

At Measurement Mode, press  button for more than 3 sec. to display [F-01]. Press  or  button to select other setting functions. Press  for 3 sec. at Function Setting Mode to return to Measurement Mode.

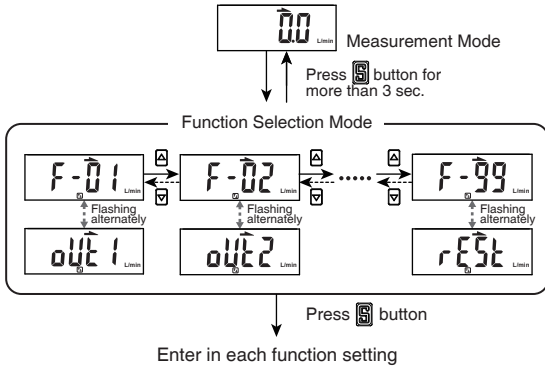

2 [F-01] OUT1 Setting Selection

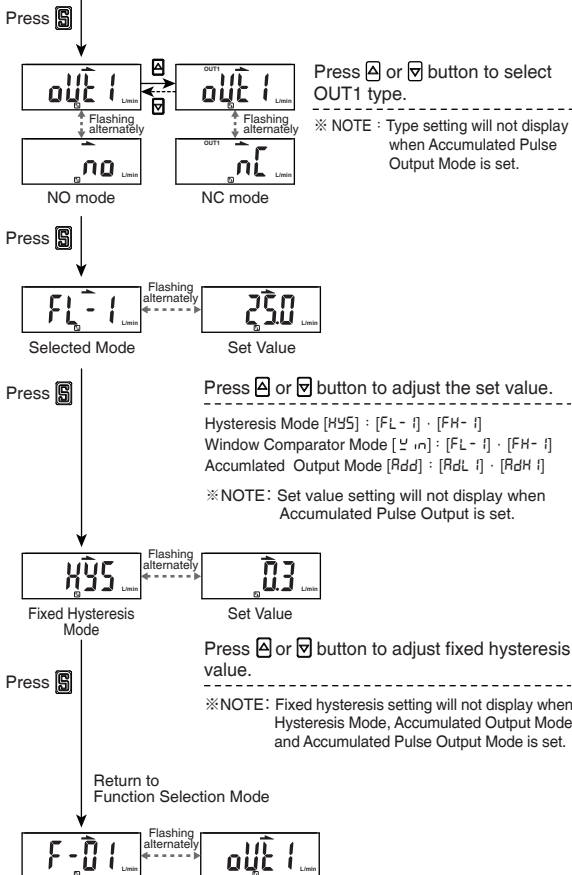
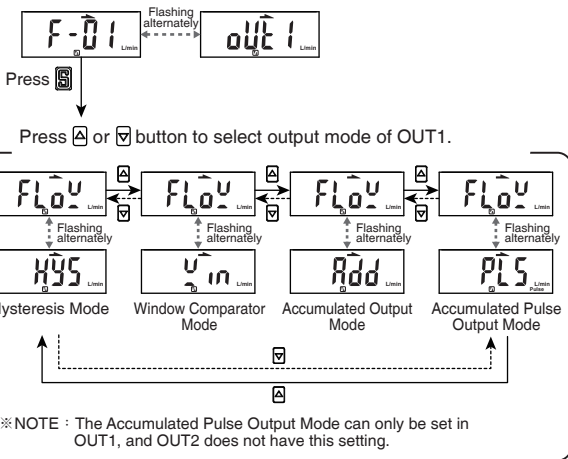

3 [F-02] OUT2 Setting Selection

※ Check the [F-01] for the same follow setting.

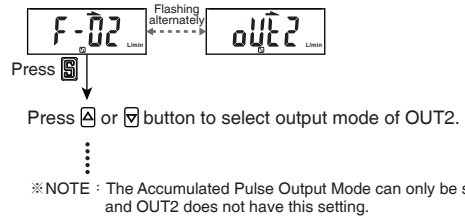

Normal Open Mode

Hysteresis Mode

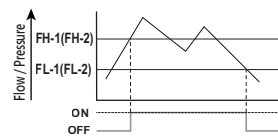

Window Comparator Mode

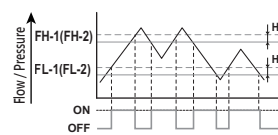

Accumulated Output Mode

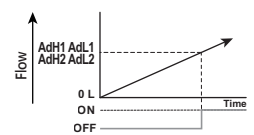

Accumulated Pulse Output Mode

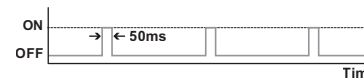

Flow Range	500mL	1000mL	5L	10L	50L	100L	200L
Pulse Output Rate	5mL	10mL	0.05L	0.1L	0.5L	1L	2L

※ NOTE:

- In case hysteresis is set at less than or equal to 2 digits, switch output may chatter if input detected fluctuates near the set point.
- When using window comparator mode, the difference between two set points must be greater than the fixed hysteresis, otherwise will cause the switch output to malfunction.

4 [F-07] Flow Reference Standard Selection

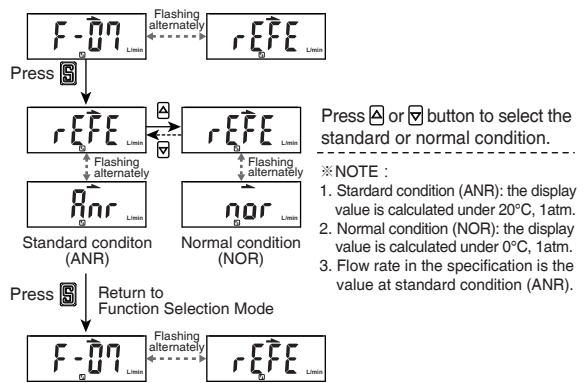

5 [F-08] Display rotation

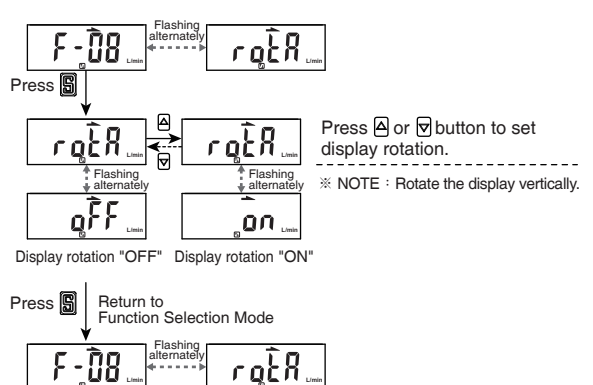

D. OPERATION INSTRUCTIONS

6 [F-10] Flow Sensor Display Mode Selection

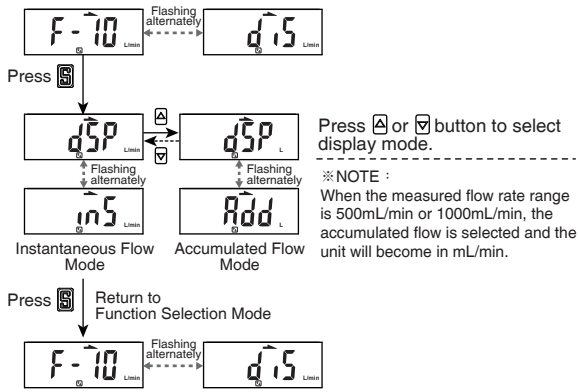

7 [F-80] Sync the value of flow analog output and display

※ This function is not available with Output Specification -02 and -04.

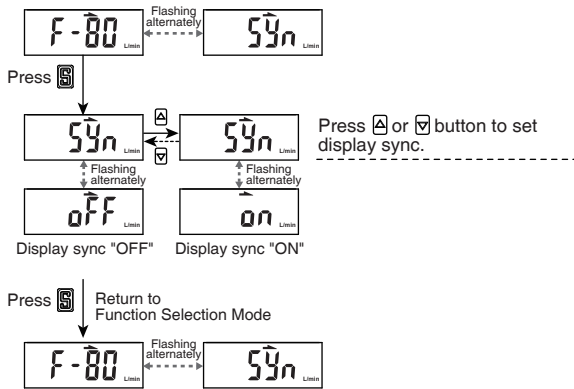

8 [F-93] Modbus RTU Setting

※ This function only available for Output Specification -02 and -04.

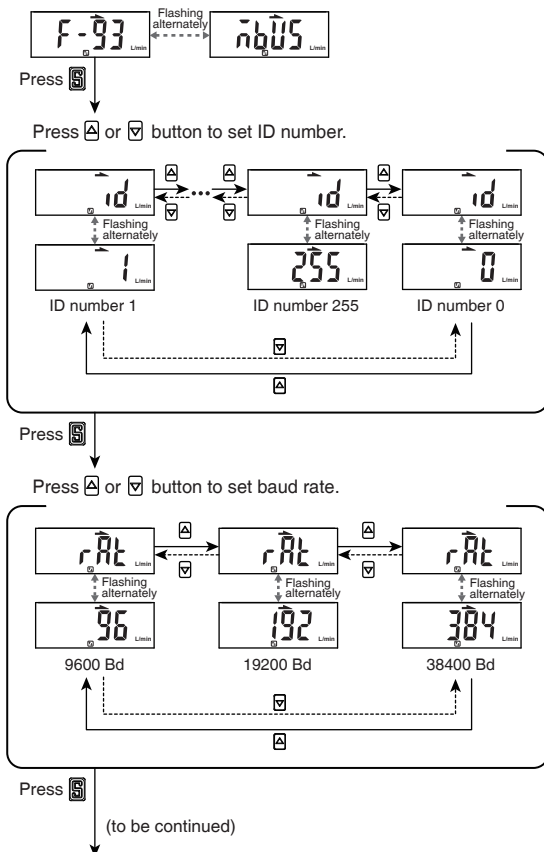

Press **[A]** or **[V]** button to set transmission format.

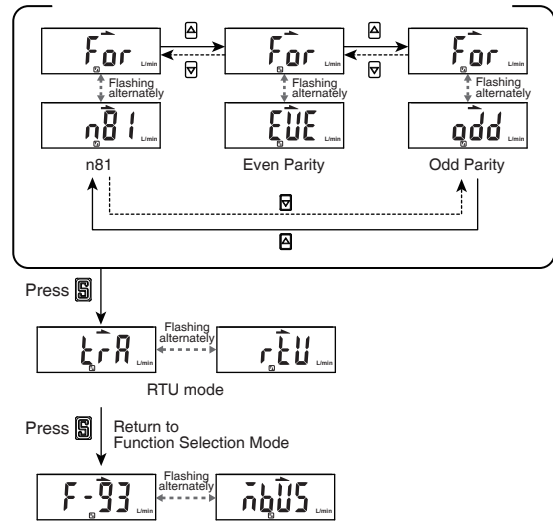

9 Instantaneous Flow Zero Adjustment Function

The displayed value can be adjusted to "0" when the measured flow is within $\pm 5\%$ F.S. of the zero point at the time of shipment from the factory.

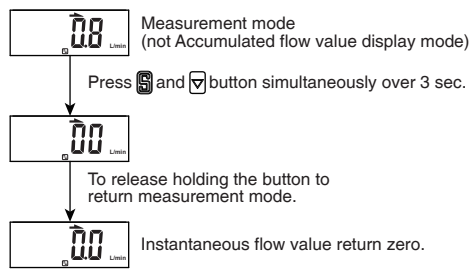

10 Reset Accumulated Flow Function

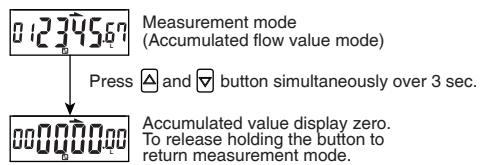

11 Key Lock / Unlock Mode

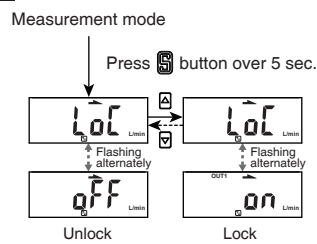

※ NOTE: If a button operation is performed while the key lock setting is ON, [LoC] will be displayed.

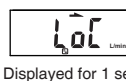

E. Modbus RTU INSTRUCTIONS

Function Code	Explanation	Operation
0000H	ID Number (0 ~ 255) Range : 0 ~ 255	Read Write
0001H	Baud rate setting 0 : 9600 bps 1 : 19200 bps 2 : 38400 bps	Read Write
0002H	Transmission format setting 0 : N.8.1 1 : E.8.1 2 : O.8.1	Read Write
0003H	Communications protocol setting 0 : RTU	Read Write
0004H	Measured flow rate range 0 : 500 mL/min 1 : 1000 mL/min 2 : 5 L/min 3 : 10 L/min 4 : 50 L/min 5 : 100 L/min 6 : 200 L/min	Read
0005H	Instantaneous flow value	Read
0006H	Flow unit 0 : LPM (L/min or mL/min) 1 : CFM (ft ³ /min)	Read Write
0007H	Decimal place for flow value 0 : None 1 : One decimal place 0.1 2 : Two decimal places 0.01 3 : Three decimal places 0.001	Read
0008H	Accumulated flow value (ADL) XXXX 9999	Read
0009H	Accumulated flow value (ADH) 9999 XXXX	Read
000AH	Flow reference standard 0 : ANR (Standard condition) 1 : NOR (Normal condition)	Read Write
000BH	Flow sensor display mode 0 : Instantaneous flow 1 : Accumulated flow	Read Write
000CH	Accumulated value hold 0 : None 1 : 2min /times 2 : 5min/times	Read Write
000DH	Flow display refresh time 0 : 200ms 1 : 500ms 2 : 1000ms	Read Write
000EH	Fine adjustment of display value -25 ~ 25 (-2.5% ~ +2.5%)	Read Write
000FH	Response time of flow sensor 0 : 50ms 1 : 80ms 2 : 120ms 3 : 200ms 4 : 400ms 5 : 800ms 6 : 1500ms	Read Write
0010H	OUT1 output mode 0 : HYS 1 : WIN 2 : ADD 3 : PLS	Read Write

Function Code	Explanation	Operation
0011H	OUT1 output type 0 : N.O. mode 1 : N.C. mode	Read Write
0012H	Flow setting value FL-1	Read Write
0013H	Flow setting value FH-1	Read Write
0014H	Flow setting value ADL1	Read Write
0015H	Flow setting value ADH1	Read Write
0016H	Fixed hysteresis setting for flow value HYS 0 ~ 8	Read Write
0017H	OUT1 switch 0 : OFF 1 : ON	Read
0018H	OUT2 output mode 0 : HYS 1 : WIN 2 : ADD	Read Write
0019H	OUT2 output type 0 : N.O. mode 1 : N.C. mode	Read Write
001AH	Flow setting value FL-2	Read Write
001BH	Flow setting value FH-2	Read Write
001CH	Flow setting value ADL2	Read Write
001DH	Flow setting value ADH2	Read Write
001EH	Fixed hysteresis setting for flow value HYS 0 ~ 8	Read Write
001FH	OUT2 switch 0 : OFF 1 : ON	Read
0020H	Color display for OUT1 or OUT2 selection 0 : OUT1 1 : OUT2	Read Write
0021H	Display color setting 0 : SOG (Switch on Green) 1 : SOR (Switch on Red) 2 : GRN (Always is Green) 3 : RED (Always is Red)	Read Write
0022H	Power-save mode 0 : NO 1 : YES	Read Write
0023H	Reset to the default setting 0 : RECALL	Write
0024H	Instant flow zero adjustment 0 : When over $\pm 5\%$ F.S., error code 03H will show.	Write
0025H	Reset accumulated flow 0 : Accumulated flow value return to zero	Write
0026H	Key lock/unlock setting 0 : OFF 1 : ON	Read Write
0027H	Switch output 0 : NPN 1 : PNP	Read
0028H	Display rotation setting 0 : OFF 1 : ON	Read Write





F. FUNCTION INSTRUCTION

Function Code	Item	Explanation
[F-01]	[OUT1] OUT 1 setting	Select Output 1 flow value to switch ON/OFF.
[F-02]	[OUT2] OUT 2 setting	Select Output 2 flow value to switch ON/OFF.
[F-03]	[LCD] LCD Display color selection	Select back light color and display mode.
[F-04]	[RESP] Response time selection	Select the response time in 50ms, 80ms, 120ms, 200ms, 400ms or 1500ms for analog output.
[F-05]	[REFR] Display refresh time selection	Display refresh cycle can be set in 200ms, 500ms or 1000ms.
[F-06]	[UNIT] Unit selection	Select the UNIT of flow sensor.
[F-07]	[REFE] Flow reference standard selection	Select the flow value is shown under standard (ANR) or normal condition (NOR).
[F-08]	[ROT] Display rotation	Set display rotation.
[F-09]	[EPR] Accumulated value hold selection	To save the last accumulated flow value every 2 or 5 minutes.
[F-10]	[DIS] Flow sensor display mode selection	Select to display Instantaneous Flow or Accumulated Flow Mode.
[F-80]	[SYNC] Sync the value of flow analog output and display	Turn ON to synchronize the value of flow analog output and display. (*1) (Default setting : OFF)
[F-91]	[ECS] Power-Save mode selection	Select if turn on power-save mode to reduce power consumption.
[F-92]	[INP] External input selection	Select for Accumulated flow rate zero clear, Auto-Shift or Auto-Shift zero. (*1)
[F-93]	[MOD5] Modbus RTU setting	Set ID number, baud rate and transmission format. (*2)
[F-94]	[FINE] Fine adjustment setting	The displayed value can be adjusted slightly.
[F-95]	[FORC] Forced output function	To force output ON/OFF to test the switch function.
[F-99]	[RESET] Reset to the default setting	Return to the factory default setting.

※ Note :

1. This function is not available with Output Specification -02 and -04.
2. This function only available for Output Specification -02 and -04.

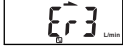
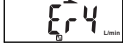
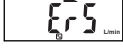
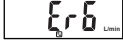
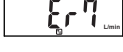
G. ERROR CODE INSTRUCTION

Error Type	Error Code	Error Condition	Troubleshooting
OUT1 Excess Load Current Error		Output 1 load current is more than 125 mA.	Turn power off and check the cause of overload current or lower the current load under 125 mA, then restart.
OUT2 Excess Load Current Error		Output 2 load current is more than 125 mA.	
Zero Adjustment Error		The instant flow is within $\pm 5\%$ F.S. of the zero point.	Perform the zero clear function again under no flow conditions.
System Error		Memory error	Turn power off, and then restart. If error condition remains, please return to factory for inspection.
		Internal data error	
		Internal data error	
		System parameter error	
Applied Flow/ Pressure Error		The instant flow has exceeded the upper limit of the flow display range.	Reduce the flow to the display range.
		The instant flow has exceeded the lower limit of the flow display range.	Ensure the flow is in the correct direction.