

For your safety, please read the following before using.

- ① Do not use corrosive fluid SUS316L, please confirm the specification in detailed.
- ② Please use within the rating pressure range. Do not apply pressure beyond recommended maximum withstand pressure, permanent damage to the pressure sensor may occur.
- ③ Do not drop, hit or allow excessive shock. Even if switch body appears undamaged, internal components may be broken and can cause malfunction.
- ④ Turn power off before connecting wiring. Wrong wiring or short circuit will damage and/or cause malfunction.
- ⑤ This product is not explosion-proof rated. Do not use in atmosphere containing flammable or explosive gases.
- ⑥ Wiring for pressure sensor should avoid power source line and high voltage line. If use in the same circuit, noise may cause malfunction.
- ⑦ The product is complied CE certificate, but no surge absorber. If required, please find other way to solve.
- ⑧ Do not exceed the screw-in torque of 13.6 N.m when installing piping. Exceeding this value may cause malfunction.
- ⑨ To prevent product damage due to short circuit, MUST do RS485 line connection BEFORE power line connection.

A. SPECIFICATIONS		EP75C (Compound)	EP75P (Positive)	EP75H02 (High)	EP75H07 (High)	EP75H10 (High)	EP75H25 (High)	EP75H40 (High)
Rated pressure range		-100.0 ~ 100.0 kPa	0.000 ~ 1.000 MPa	0.000 ~ 2.00 MPa	0.00 ~ 7.00 MPa	0.00 ~ 10.00 MPa	0.0 ~ 25.0 MPa	0.0 ~ 40.0 MPa
Setting pressure range		-101.0~101.0 kPa	-0.100~1.000 MPa	-0.100~2.00 MPa	0.00 ~ 7.00 MPa	0.00 ~ 10.00 MPa	0.0 ~ 25.0 MPa	0.0 ~ 40.0 MPa
Withstand pressure		300 kPa	3 MPa	3 MPa	14 MPa	20 MPa	50 MPa	80 MPa
Fluid		Fluids do not corrode stainless steel 316L			Fluids do not corrode stainless steel 316L, fluororubber (FKM)			
Sealed liquid		Silicon oil						
Set pressure resolution	kPa	0.1	—	—	—	—	—	—
	MPa	—	0.001	0.001(-1.999) 0.01(2.00~)	0.01	0.01	0.1	0.1
	kgf/cm ²	0.001	0.01	0.01(-19.99) 0.1(20.0~)	0.1	0.1	1	1
	bar	0.001	0.01	0.01(-19.99) 0.1(20.0~)	0.1	0.1	1	1
	psi	0.01	0.1	0.1(-199.9) 1(200~)	1	1	1 (*1)	1 (*1)
	inHg	0.1	—	—	—	—	—	—
Power supply voltage		12 to 24V DC ±10%, Ripple (P-P) 10% or less						
Current consumption		≤ 40mA (With no load)						
Switch output	Output type	1 NPN or 1 PNP open collector						
	Max. load current	125 mA						
	Max. supply voltage	1 NPN 30V DC, 1PNP 24V DC						
	Residual voltage	≤ 1.5V						
	Response time	≤ 2.5ms (chattering-proof function: 25ms, 100ms, 250ms, 500ms, 1000ms and 1500ms selections)						
	Output short circuit protection	Yes						
Display	LCD display	3½ digit, 7segment (red/ green)						
	Switch ON Indicator	Orange (1 Indicator) OUT1						
	Updates time	About 0.2s						
	Indicator accuracy	± 2% F.S. ± 1 digit (ambient temperature: 25 ± 3°C)						
Repeatability (Switch output)		±0.3% F.S. ±1 digit						
Environment	Enclosure	IP65						
	Operation ambient temp. range	0 ~ 50°C						
	Storage ambient temp. range	-10 ~ 60°C (No condensation or freezing)						
	Ambient humidity range	35 ~ 85% RH (No condensation)						
	Withstand voltage	250V AC in 1-min (between case and lead wire)						
	Insulation resistance	50MΩ (at 500V DC, between case and lead wire)						
	Vibration	Total amplitude 1.5mm or 10G,10Hz-55Hz-10Hz scan for 1 minute, two hours each direction of X, Y and Z						
	Shock	100m/s ² (10G), 3 times each in direction of X, Y and Z						
Temperature characteristic		±3% F.S. of detected pressure (25°C) at temp. Range of 0~50°C						
Port size (*2)		F1:R1/4", M5; F2:NPT1/4", #10-32 UNF; F3: G1/4"(BSPP), M5						
Lead wire		Oil-resistance cable(0.15mm ²)						
Weight (With 2 meter lead wire)		Approx. 110g (Rear ported); Approx. 150g (Bottom ported)						

*1. When using a unit psi, the actual value is display value multiply by ten (x10).

*2. G port O-Ring material is NBR, if any special request, please contact us.

B. ORDERING INFORMATION

EP75 **C** - **02** - **F1** **□**

Pressure Range

C : Compound (-101.0~101.0 kPa)
 P : Positive (-0.100~1.000 MPa)
 H02 : High (-0.100~2.00 MPa)
 H07 : High (0.00~7.00 MPa)
 H10 : High (0.00~10.00 MPa)
 H25 : High (0.0~25.0 MPa)
 H40 : High (0.0~40.0 MPa)

Output Specifications

02 : 1 NPN Output + RS485
 04 : 1 PNP Output + RS485

Pressure Port

F1 : R1/4", M5
 F2 : NPT1/4", #10-32UNF
 F3 : G1/4"(BSPP), M5

Piping Direction

Blank : Rear ported
 L : Bottom ported

Optional Parts

BT-10 : Mounting bracket
 BT-11 : Mounting bracket
 PA-E : Panel adapter
 PA-F : Panel adapter + Front protective lid
 I-0360 : Snubber (for Pressure Port F1&F3)
 I-0379 : Snubber (for Pressure Port F2)

*EP75P and EP75H are recommended to install a snubber to reduce shock effects. See Section "Q".

C. PANEL DESCRIPTION

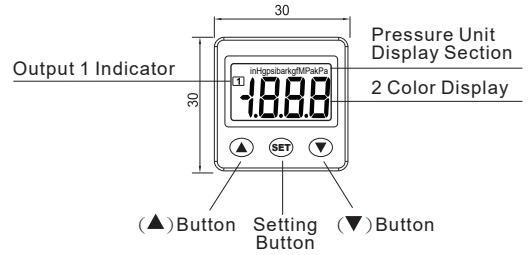

D. OUTPUT CIRCUIT WIRING DIAGRAMS

EP75□-02-□
 1 NPN+RS485

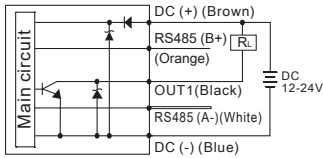

EP75□-04-□
 1 PNP+RS485

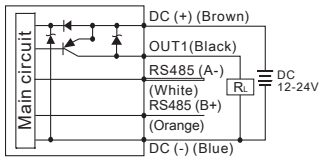

E. DIMENSIONS

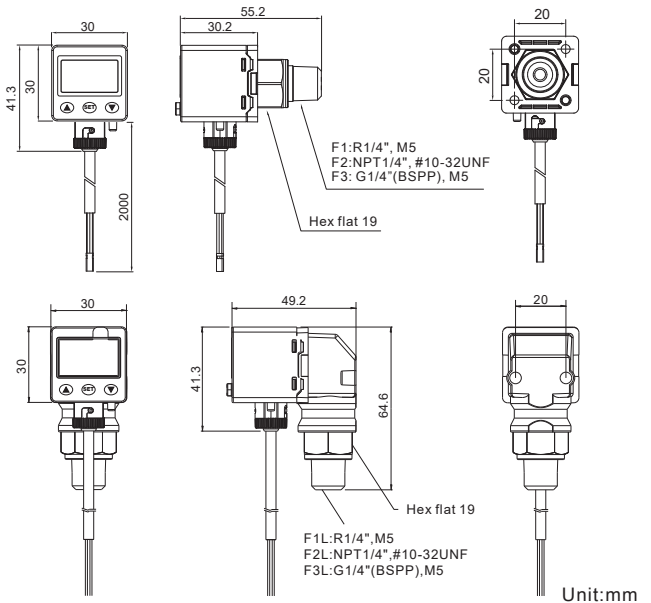

F. OPTIONAL PARTS DIMENSIONS

① Mounting bracket

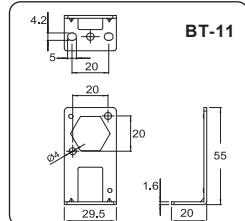
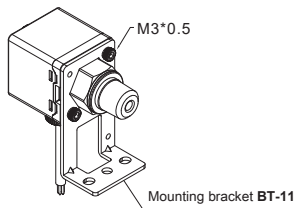
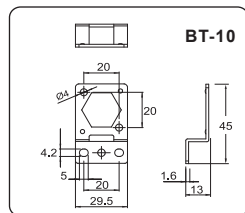
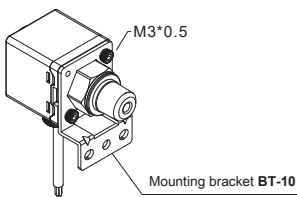

③ Accessory

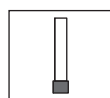
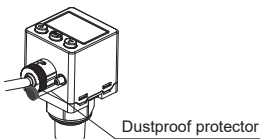

Caution:
 This device must be installed to maintain IP 65 (Dust and splash proof) enclosure rating.

② Panel Mounting

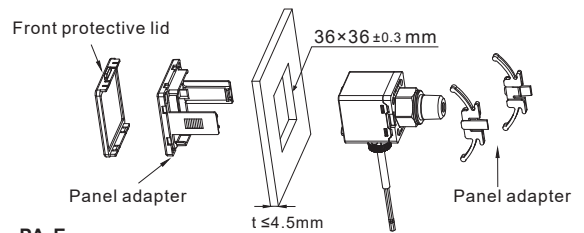

PA-E

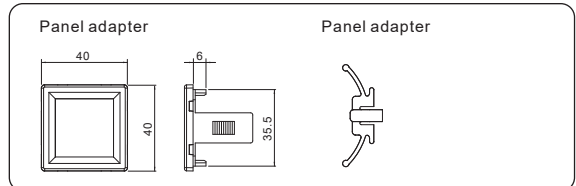

PA-F

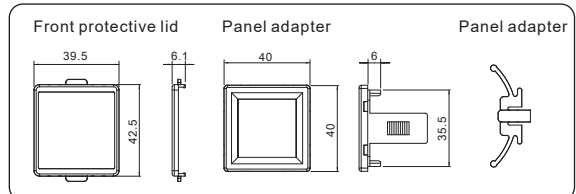

Unit:mm

G. INITIAL SETTING MODE

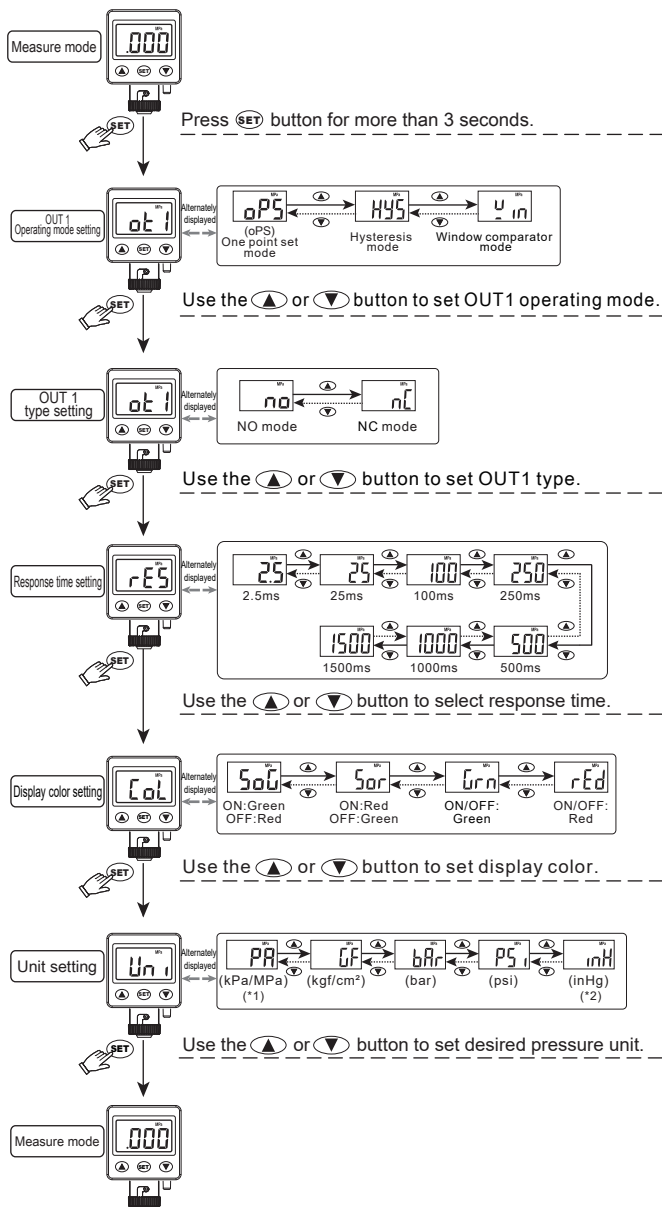

[NOTE :]

- *1. Pressure unit is MPa with positive and high pressure. Pressure unit is kPa with compound pressure.
- *2. Only applicable for Compound.

H. POWER-SAVE MODE

- ⊙ During Power-Save mode, the main display will turned off if no buttons is pressed after 30 seconds.
- ⊙ During Power-Save mode, the output LCD may not be synchronize with the output. It is normal and will not affect output operation.
- ⊙ Press any button to turn-on main display temporarily.

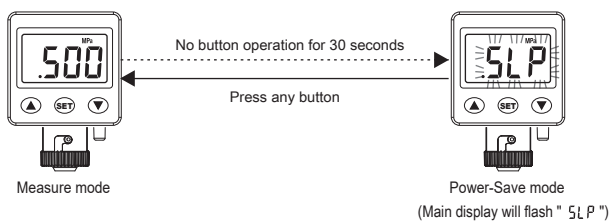

I. ADVANCE SETTING MODE

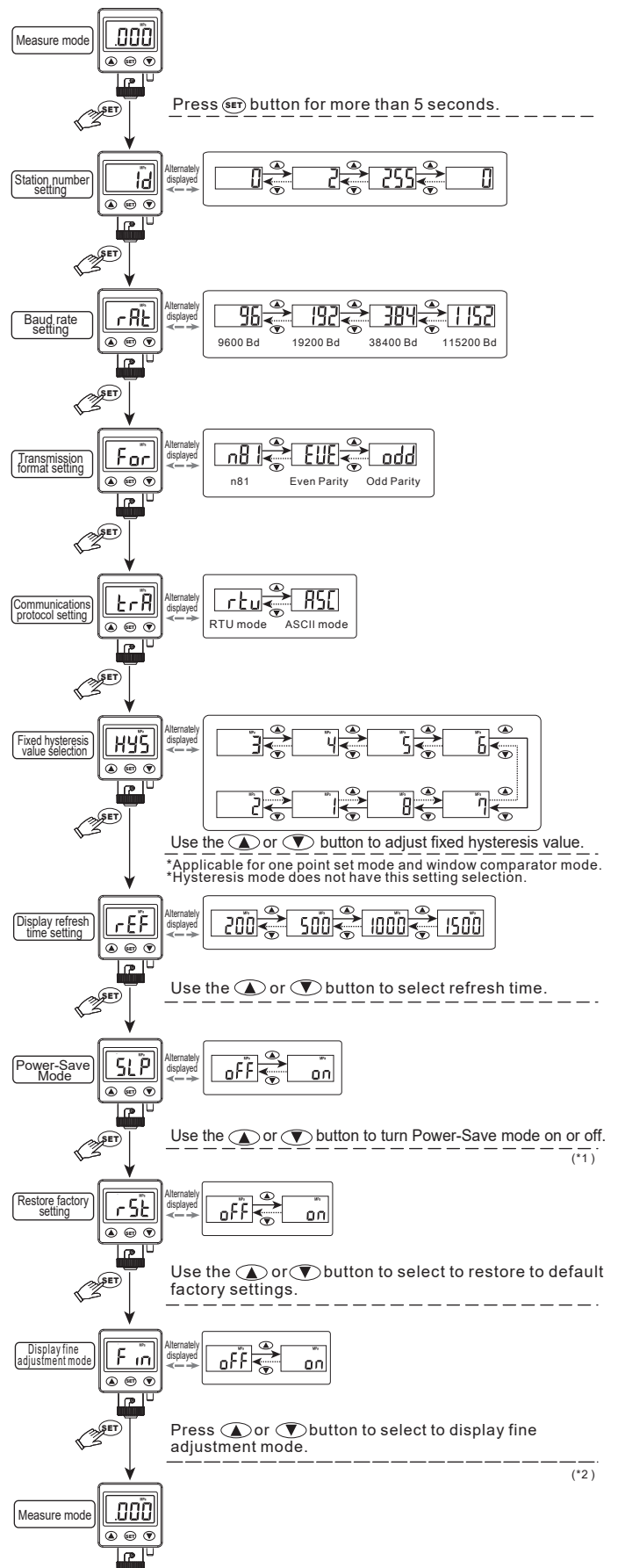

[NOTE :]

- *1. When setting is "on", the power-save mode is active. Please refer to the Section "H" for details.
- *2. When setting is "on", the display fine adjustment mode is active. Please refer to the Section "R" for details.

J. PRESSURE SETTING MODE

⊙ One point set mode :

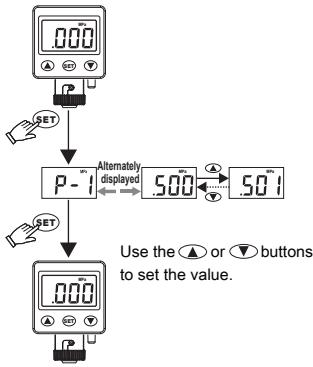

⊙ Hysteresis mode / Window comparator mode :

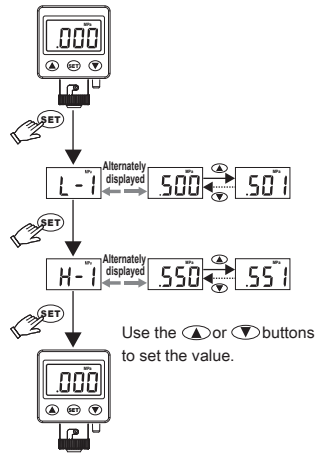

K. OUTPUT TYPE

(1) One point set mode:

Normal open mode

High / Compound / Positive (EP75H / EP75C / EP75P)

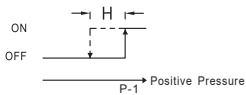

Normal close mode

High / Compound / Positive (EP75H / EP75C / EP75P)

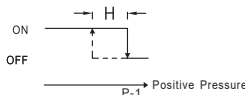

(2) Hysteresis mode:

Normal open mode

High / Compound / Positive (EP75H / EP75C / EP75P)

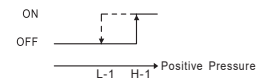

Normal close mode

High / Compound / Positive (EP75H / EP75C / EP75P)

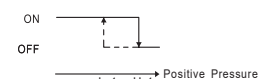

(3) Window comparator mode:

Normal open mode

High / Compound / Positive (EP75H / EP75C / EP75P)

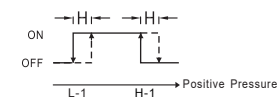

Normal close mode

High / Compound / Positive (EP75H / EP75C / EP75P)

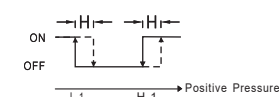

[NOTE:]

- *1. In case hysteresis is set at less than or equal to 2 digits, switch output may chatter if input pressure fluctuates near the set point.
- *2. When using window comparator mode, the difference between two set points must be greater than the fixed hysteresis, otherwise will cause the switch output to malfunction.

L. COMMUNICATION PROTOCOL (Modbus RTU)

(1) Computer /PLC transmit data format (Master)

ID Number 1 Byte	Read 1 Byte	Function Code 2 Byte	Data Number 2 Byte	CRC CheckSum 2 Byte
---------------------	----------------	-------------------------	-----------------------	------------------------

(2) Pressure sensor response data format (Slave <EP75>)

ID Number 1 Byte	Read 1 Byte	Data Number 1 Byte	Data 2N Byte(*)	CRC CheckSum 2 Byte
---------------------	----------------	-----------------------	--------------------	------------------------

* N is the number of data

(3) Computer /PLC transmit data format (Master)

ID Number 1 Byte	Write 1 Byte	Function Code 2 Byte	Data 2 Byte	CRC CheckSum 2 Byte
---------------------	-----------------	-------------------------	----------------	------------------------

(4) Pressure sensor response data format (Slave <EP75>)

ID Number 1 Byte	Write 1 Byte	Function Code 2 Byte	Data 2 Byte	CRC CheckSum 2 Byte
---------------------	-----------------	-------------------------	----------------	------------------------

(5) Pressure sensor response data format (Error)

ID Number 1 Byte	Write 1 Byte	Error Code 1 Byte	CRC CheckSum 2 Byte
---------------------	-----------------	----------------------	------------------------

(6) Read / Write Code

Read / Write Code	Description
03H	Read pressure sensor data Range 1~4 data Number, 2~8 Bytes
06H	Write pressure sensor data

(7) Example : Read pressure sensor value
Computer /PLC transmit data format (Master)

ID Number (01H)	Read (03H)	Function Code (0002H)	Data Number (0001H)	CRC CheckSum (25CAH)
--------------------	---------------	--------------------------	------------------------	-------------------------

Pressure sensor data format

ID Number (01H)	Read (03H)	Data Number (02H)	Data (0001H)	CRC CheckSum (7984H)
--------------------	---------------	----------------------	-----------------	-------------------------

(8) Example : ID Number setting response
Computer /PLC transmit data format (Master)

ID Number (01H)	Write (06H)	Function Code (0000H)	Data (0001H)	CRC CheckSum (480AH)
--------------------	----------------	--------------------------	-----------------	-------------------------

Pressure sensor response data

ID Number (01H)	Write (06H)	Function Code (0000H)	Data (0001H)	CRC CheckSum (480AH)
--------------------	----------------	--------------------------	-----------------	-------------------------

Example : ID Number setting response error

ID Number (01H)	Write (06H)	Function Code (0000H)	Data (01FFH)	CRC CheckSum (C81AH)
--------------------	----------------	--------------------------	-----------------	-------------------------

Pressure sensor response error (Example : setting data is over)

ID Number (01H)	Write (86H)	Error Code (03H)	CRC CheckSum (0261H)
--------------------	----------------	---------------------	-------------------------

(When the pressure sensor is abnormal, MSB will be set to 1, so the command code is 86H)

(9) Function Code :

Function Code	Description	Operation
0000H	ID Number (Range:0~255)	Read / Write
0001H	Pressure Type (1:Compound 3:Positive 4:H02 6:H07 7:H10 8:H25 9:H40)	Read
0002H	Pressure Value	Read
0003H	Unit (0:kPa 1:kgf 2:bar 3:psi 4:inHg 5:mmHg 6:MPa)	Read / Write
0004H	Decimal dot (Range:0~3 digit)	Read
0005H	Switch operation mode (0:ops 1:hys 2:win)	Read / Write
0006H	Switch operation type (0:NO 1:NC)	Read / Write
0007H	Response time (0:2.5ms 1:25ms 2:100ms 3:250ms 4:500ms 5:1000ms 6:1500ms)	Read / Write
0008H	Display color select (0:SOG 1:SOR 2:GRN 3:RED)	Read / Write
0009H	Fixed hysteresis value selection (Range : 1~8)	Read / Write
000AH	Power-save mode (0:OFF 1:ON)	Read / Write
000BH	Display fine adjustment mode (Range : -25%~25%) (The actual display is : -2.5%~2.5%)	Read / Write
000CH	Baud rate setting (0:9600 1:19200 2:38400 3:115200)	Read / Write
000DH	Transmission format setting (0:N,8,1 1:E,8,1 2:O,8,1)	Read / Write
000EH	Communications protocol setting (0:RTU / 1:ASC)	Read / Write
000FH	Restore factory setting(write range: 0 or 1)	Write
0010H	Operation point setting ; P-1 or L-1 (Range : According to pressure type and unit)	Read / Write
0011H	Operation point setting ; H-1 (Range : According to pressure type and unit)	Read / Write
0012H	Switch state (0:OFF 1:ON)	Read
0013H	Key lock function (0:OFF 1:ON)	Read / Write
0014H	Switch type (0:NPN 1:PNP)	Read
0015H	Display refresh time setting (0:200ms 1:500ms 2:1000ms 3:1500ms)	Read / Write
0016H	Zero reset (If ambient pressure is over ±3% F.S. , error code shows 03H)	Write

(10) Error Code Description :

Error Code	Description
01H	Read / Write error
02H	Function Code error
03H	Illegal data or over setting value

M. COMMUNICATION PROTOCOL (Modbus ACSII)

(1) Computer /PLC transmit data format (Master)

Head 1 Byte	ID Number 2 Byte	Read 2 Byte	Function Code 4 Byte	Data Number 2 Byte	LRC CheckSum 2 Byte	Trailer CR+LF 2 Byte
----------------	---------------------	----------------	-------------------------	-----------------------	------------------------	-------------------------

(2) Pressure sensor response data format (Slave <EP75>)

Head 1 Byte	ID Number 2 Byte	Read 2 Byte	Function Code 2 Byte	Data 4N Byte(*)	LRC CheckSum 2 Byte	Trailer CR+LF 2 Byte
----------------	---------------------	----------------	-------------------------	--------------------	------------------------	-------------------------

* N is the number of data

(3) Computer /PLC transmit data format (Master)

Head 1 Byte	ID Number 2 Byte	Write 2 Byte	Function Code 4 Byte	Data 4 Byte	LRC CheckSum 2 Byte	Trailer CR+LF 2 Byte
----------------	---------------------	-----------------	-------------------------	----------------	------------------------	-------------------------

(4) Pressure sensor response data format (Slave <EP75>)

Head 1 Byte	ID Number 2 Byte	Write 2 Byte	Function Code 4 Byte	Data 4 Byte	LRC CheckSum 2 Byte	Trailer CR+LF 2 Byte
----------------	---------------------	-----------------	-------------------------	----------------	------------------------	-------------------------

(5) Pressure sensor response data format (Error)

Head 1 Byte	ID Number 2 Byte	Write 2 Byte	Error Code 2 Byte	LRC CheckSum 2 Byte	Trailer CR+LF 2 Byte
----------------	---------------------	-----------------	----------------------	------------------------	-------------------------

(6) Read / Write Code

Read / Write Code	Description
30H33H	Read pressure sensor data Range 1~4 data Number , 4~16 Bytes
30H36H	Write pressure sensor data

(7) Example : Read pressure sensor value
Computer /PLC transmit data format (Master)

Head (3AH)	ID Number (30H31H)	Read (30H33H)	Function Code (30H30H30H32H)	Data Number (30H30H30H31H)	LRC CheckSum (46H39H)	Trailer (0DH0AH)
---------------	-----------------------	------------------	---------------------------------	-------------------------------	--------------------------	---------------------

Pressure sensor response data format

Head (3AH)	ID Number (30H31H)	Read (30H33H)	Data Number (30H30H30H31H)	Data (30H30H30H31H)	LRC CheckSum (46H39H)	Trailer (0DH0AH)
---------------	-----------------------	------------------	-------------------------------	------------------------	--------------------------	---------------------

(8) Example : ID Number setting response
Computer /PLC transmit data format (Master)

Head (3AH)	ID Number (30H31H)	Write (30H36H)	Function Code (30H30H30H30H)	Data (30H30H30H31H)	LRC CheckSum (46H38H)	Trailer (0DH0AH)
---------------	-----------------------	-------------------	---------------------------------	------------------------	--------------------------	---------------------

Pressure sensor response data

Head (3AH)	ID Number (30H31H)	Write (30H36H)	Function Code (30H30H30H30H)	Data (30H30H30H31H)	LRC CheckSum (46H38H)	Trailer (0DH0AH)
---------------	-----------------------	-------------------	---------------------------------	------------------------	--------------------------	---------------------

Example : ID Number setting response error

Head (3AH)	ID Number (30H31H)	Write (30H36H)	Function Code (30H30H30H30H)	Data (30H31H46H46H)	LRC CheckSum (46H39H)	Trailer (0DH0AH)
---------------	-----------------------	-------------------	---------------------------------	------------------------	--------------------------	---------------------

Pressure sensor response error (Example : setting data is over)

Head (3AH)	ID Number (30H31H)	Write (38H36H)	Error Code (30H33H)	LRC CheckSum (37H36H)	Trailer (0DH0AH)
---------------	-----------------------	-------------------	------------------------	--------------------------	---------------------

(When the pressure sensor is abnormal, MSB will be set to 1, so the command code is 38H36H)



(9) Function Code :

Function Code	Description	Operation
30H30H30H30H	ID Number (Range:0~255)	Read / Write
30H30H30H31H	Pressure Type (1:Compound 3:Positive 4:H02 6:H07 7:H10 8:H25 9:H40)	Read
30H30H30H32H	Pressure Value	Read
30H30H30H33H	Unit (0:kPa 1:kgf 2:bar 3:psi 4:inHg 5:mmHg 6:MPa)	Read / Write
30H30H30H34H	Decimal dot (Range:0~3 digit)	Read
30H30H30H35H	Switch operation mode (0:ops 1:hys 2:win)	Read / Write
30H30H30H36H	Switch operation type (0:NO 1:NC)	Read / Write
30H30H30H37H	Response time (0:2.5ms 1:25ms 2:100ms 3:250ms 4:500ms 5:1000ms 6:1500ms)	Read / Write
30H30H30H38H	Display color select (0:SOG 1:SOR 2:GRN 3:RED)	Read / Write
30H30H30H39H	Fixed hysteresis value selection (Range : 1~8)	Read / Write
30H30H30H41H	Power-save mode (0:OFF 1:ON)	Read / Write
30H30H30H42H	Display fine adjustment mode (Range : -25%~25%) (The actual display is : -2.5%~2.5%)	Read / Write
30H30H30H43H	Baud rate setting (0:9600 1:19200 2:38400 3:115200)	Read / Write
30H30H30H44H	Transmission format setting (0:N,8,1 1:E,8,1 2:O,8,1)	Read / Write
30H30H30H45H	Communications protocol setting (0:RTU / 1:ASC)	Read / Write
30H30H30H46H	Restore factory setting(write range: 0 or 1)	Write
30H30H31H30H	Operation point setting ; P-1 or L-1 (Range : According to pressure type and unit)	Read / Write
30H30H31H31H	Operation point setting ; H-1 (Range : According to pressure type and unit)	Read / Write
30H30H31H32H	Switch state (0:OFF 1:ON)	Read
30H30H31H33H	Key lock function (0:OFF 1:ON)	Read / Write
30H30H31H34H	Switch type (0:NPN 1:PNP)	Read
30H30H31H35H	Display refresh time setting (0:200ms 1:500ms 2:1000ms 3:1500ms)	Read / Write
30H30H31H36H	Zero reset (If ambient pressure is over 33% F.S. , error code shows 30H33H)	Write

(10) Error Code Description :

Error Code	Description
30H31H	Read / Write error
30H32H	Function Code error
30H33H	Illegal data or over setting value

N. ZERO POINT SETTING

Use the  +  button at the same time until the "00" is shown.
Release the button to end zero setting.

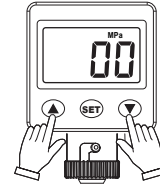

O. THE MAX. & MIN. DISPLAY MODE

◎ The Max. value display mode :

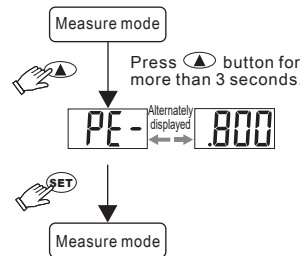

◎ The Min. value display mode :

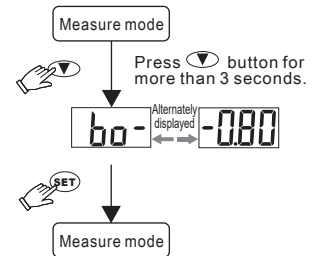

P. KEY LOCK/UNLOCK MODE

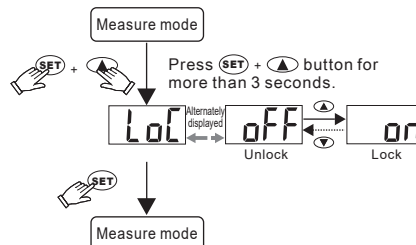

◎ Key lock mode, it displays as picture when pressing any key.
After some time, it would be returned to measure mode.

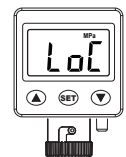

Q. REMOVABLE SNUBBER INSTALLED

Pressure port equipped with snubber can avoid damage caused by sudden pressure surge of water or oil, improve product durability.

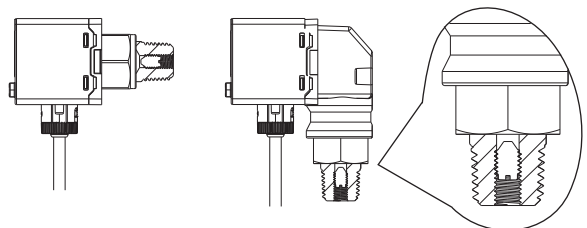

*When snubber is clogged with contaminants, please use a flat head screwdriver to remove the snubber, clean and reinstall.

R. FINE ADJUSTMENT MODE

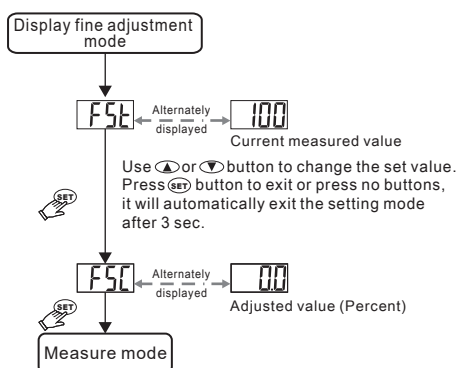

This function eliminates slight differences in the output values and allows uniformity in the numbers displayed. Displayed values of the pressure sensor can be calibrated to within $\pm 2.5\%$ R.D.

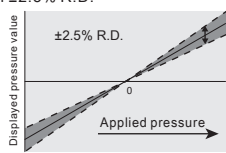

— : Factory setting display value set prior to shipment
 ■ : Display calibration range

R.D. (Real Detect)

[NOTE:] 1. Setting resolution is $\pm 0.1\%$ R.D.
 2. The signal would be changed with analog output after adjusting.

T. PRESSURE UNIT CONVERSION TABLE

From \ To	Pa	kPa	MPa	kgf/cm ²	psi	bar	inHg
1 Pa	1	0.001	0.000001	0.000010197	0.000145038	0.00001	0.0002953
1 kPa	1000.000	1	0.001000	0.010197	0.145038	0.010000	0.2953
1 MPa	1000000	1000	1	10.197	145.038	10	295.2998
1 kgf/cm ²	98066.5	98.0665	0.0980665	1	14.2233	0.980665	28.95979
1 psi	6895	6.895	0.006895	0.07031	1	0.06895	2.036074
1 bar	100000.0	100.0000	0.100000	1.01972	14.5038	1	29.52998
1 inHg	3386.388	3.386388	0.003386	0.034530	0.491141	0.033863	1

S. WIRE INSTALLATION INSTRUCTION

Please install the wire as the following step.

- Turn upward the salient point by terminal. (See figure ①)
- Install to the terminal to the groove by pressure sensor. (See figure ②)
- Terminal cover install to the products. (See figure ③)
- Turn the terminal cover to lock. (See figure ④)

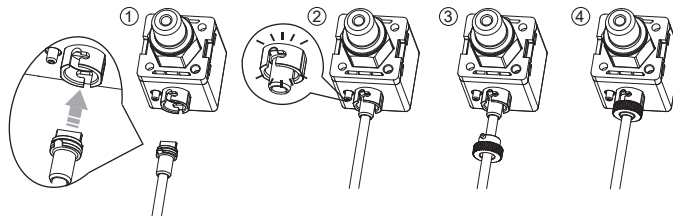

[NOTE:] Recommend not insert-extract over 20 times.

U. ERROR CODE INSTRUCTION

Error Type	Error code	Error Condition	Troubleshooting
Excess load current error	out1 Er1	Output 1 load current is more than 125 mA	Turn power off and check the cause of overload current or lower the current load under 125 mA, then restart.
Residual pressure error	Er3	During zero reset, ambient pressure is over $\pm 3\%$ F.S. (EP75H series is $\pm 1.5\%$ F.S.)	Change input pressure to ambient pressure and perform zero reset again.
Applied pressure error	HHH	Supply pressure exceeds the upper limit of pressure setting.	Adjust the pressure within operating pressure range.
	LLL	Supply pressure exceeds the lower limit of pressure setting.	
System error	Er4	Internal system error	Turn power off, and then restart. If error condition remains, please return to factory for inspection.
	Er5	Internal system error	
	Er6	Internal data error	
	Er7	Internal data error	