

C. PANEL DESCRIPTION

For your safety, please read the following before using.

- Do not use corrosive or flammable gas or liquid with this product.
- Please use within the rated pressure range. Do not apply pressure beyond recommended maximum withstand pressure, permanent damage to the pressure gage may occur.
- Do not drop, hit or allow excessive shock. Even if pressure gage body appears undamaged, internal components may be broken and can cause malfunction.
- Do not use in environment containing steam or oil vapor.
- This product is not explosion-proof rated. Do not use in atmosphere containing flammable or explosive gases.
- Using filter can extend pressure gage's service life.

A. SPECIFICATIONS

TYPE	(Vacuum)		(Positive)	
	EP60V-□	EP60VL-□	EP60P-□	EP60PL-□
Rated pressure range	0 ~ -101kPa		0.000 ~ 1.000MPa	
Display pressure range	10 ~ -101kPa		-0.100 ~ 1.000MPa *1	
Withstand pressure	300kPa		1.5MPa	
Applicable fluid	Filtered air, incombustible and non-corrosive gases			
Pressure resolution	kPa	1	—	
	MPa	—	0.001	
	kgf/cm ²	—	0.01	
	bar	0.01	0.01	
	psi	0.1	0.1	
	mmHg	1	—	
Battery	CR 2032 lithium			
Back light	No	Yes	No	Yes
Battery life	3 years (5 times/day)	1 year (5 times/day)	3 years (5 times/day)	1 year (5 times/day)
Low-power indicator	Yes			
Battery replaceable	Yes			
Turn-on interval	Display turn off after 60 sec.			
Sampling rate	2 Hz (2 times/sec.)			
Pressure unit	psi, bar, mmHg and kPa user selectable		psi, bar, kgf/cm ² and MPa user selectable	
Repeatability	±1% F.S. ±1digit		±0.2% F.S. ±1digit	
LCD display	3 ½ digit, 7 segment			
Indicator accuracy	±2% F.S. ±1 digit (ambient temperature: 25 ±3 °C)			
Environment	Enclosure	IP65 *2		
	Ambient temp. range	Operation: 0 ~ 50 °C, storage: -10 ~ 60 °C (No condensation or freezing)		
	Ambient humidity range	Operation/Storage: 35 ~ 85% RH (No condensation)		
	Vibration	Total amplitude 1.5mm or 10G, 10Hz-55Hz-10Hz scan for 1 minute, two hours each direction of X, Y and Z		
	Shock	100m/s ² (10G), 3 times each in direction of X, Y and Z		
Temperature characteristic	±2% F.S. of detected pressure (25°C) at temp. range of 0~50°C			
Port size	F1:R1/8", M5; F2:NPT1/8", #10-32 UNF; F3:G1/8"(BSPP), M5; F4:R1/4", M5; F5:NPT1/4", #10-32 UNF; F6:G1/4"(BSPP), M5			
Weight	Approx. 40g			

*1. When the pressure is -0.1MPa, LCD displays -0.00 MPa.
*2. Air tube must be installed to maintain IP65. (See section K)

B. ORDERING INFORMATION

EP60P□ - F1

Pressure Range

V : Vacuum (10 ~ -101kPa)
P : Positive (-0.100 ~ 1.000MPa)

Back Light

Blank : Back light unavailable
L : Back light available

Optional Parts

BT-5 : Mounting bracket
BT-6 : Mounting bracket
PA-C : Panel adapter
PA-D : Panel adapter + Front protective lid

Pressure Port

F1 : R1/8", M5
F2 : NPT1/8", #10-32 UNF
F3 : G1/8"(BSPP), M5
F4 : R1/4", M5
F5 : NPT1/4", #10-32 UNF
F6 : G1/4"(BSPP), M5

D. DIMENSIONS

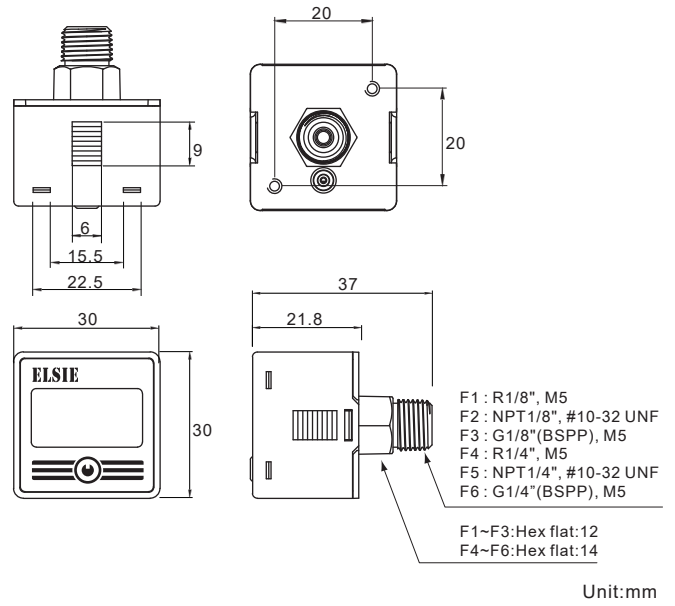

E. BATTERY STATUS / INSTALLATION

FOLLOW THE STEPS BELOW

- Using a flat screwdriver size 1.4 ~ 3.0 mm insert into the back of the pressure gage as pictured. (See figure ②)
- Turn the screwdriver horizontally 90° to separate the case and the base. Repeat this process again for the other side. (See figure ③)
- Carefully remove the outer cover (See figure ④), and follow the diagrams below to replace battery and reassembly. Polarity must be observed, incorrect battery installation will cause malfunction.

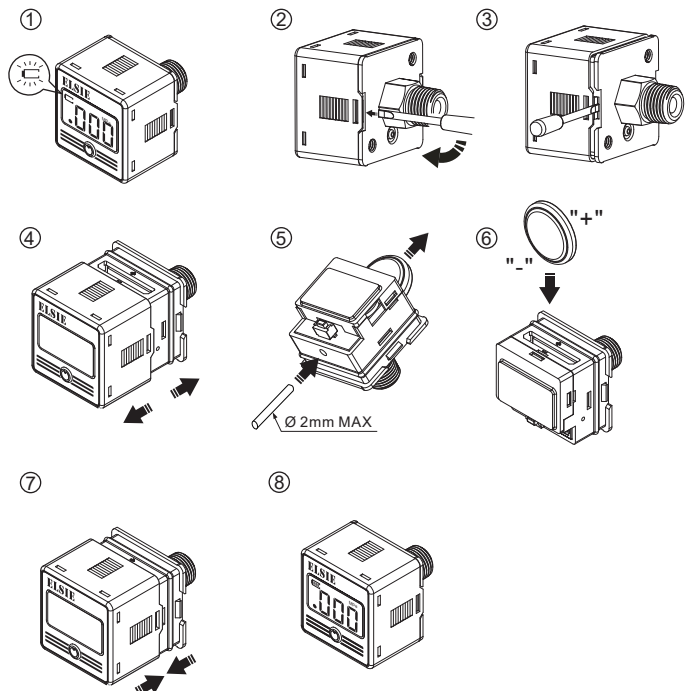

F. OPTIONAL PARTS DIMENSIONS

① Mounting bracket

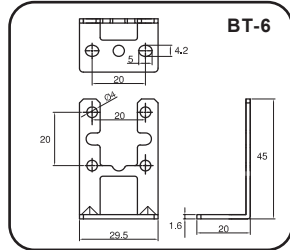
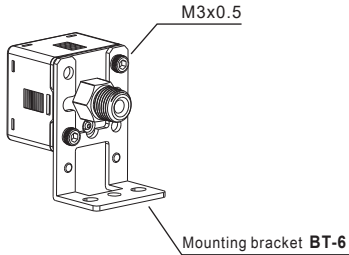
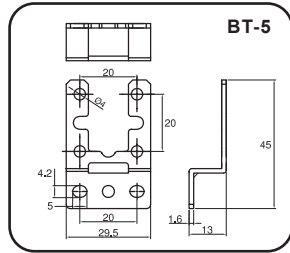
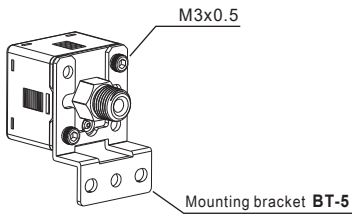

② Panel mounting

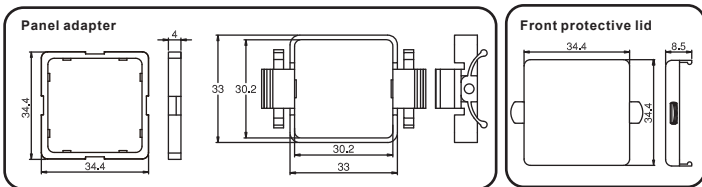
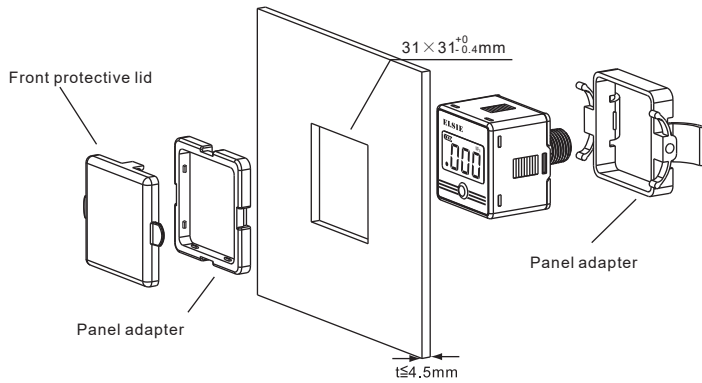

Unit:mm

G. PRESSURE UNIT CONVERSION TABLE

From	To	kPa	MPa	kgf/cm ²	mmHg	psi	bar
1 kPa		1	0.001000	0.010197	7.500616	0.145038	0.010000
1 MPa		1000	1	10.197	7500.616	145.038	10
1 kgf/cm ²		98.0665	0.0980665	1	735.559	14.2233	0.980665
1 mmHg		0.13332	0.000133	0.0013595	1	0.019336	0.0013332
1 psi		6.895	0.006895	0.07031	51.7157	1	0.06895
1 bar		100.0000	0.100000	1.01972	750.062	14.5038	1

H. POWER-SAVE MODE

- ⊙ The pressure gage will enter power saving mode if the ⊙ button is not pressed within 60 sec.
- ⊙ In measure mode, press the ⊙ button to extend display for 120 sec.

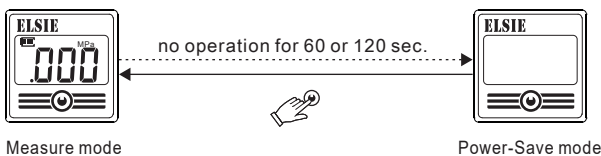

I. PRESSURE UNIT SETTING MODE

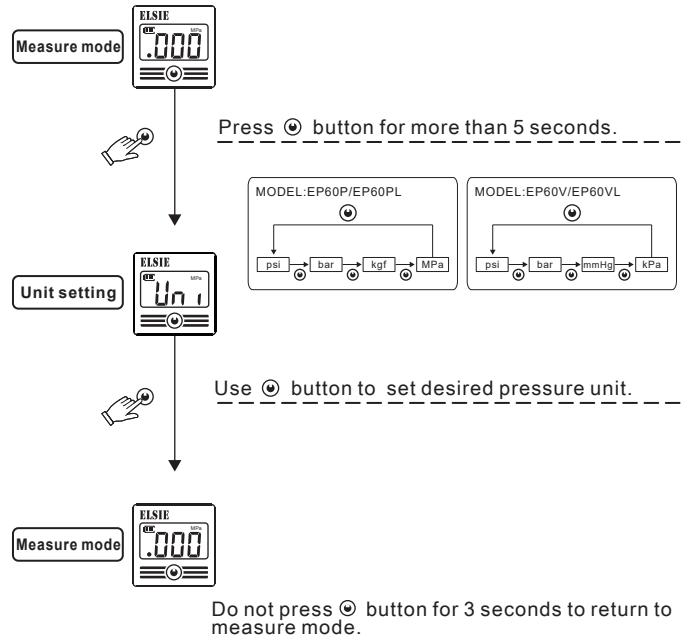

J. ZERO POINT RESET

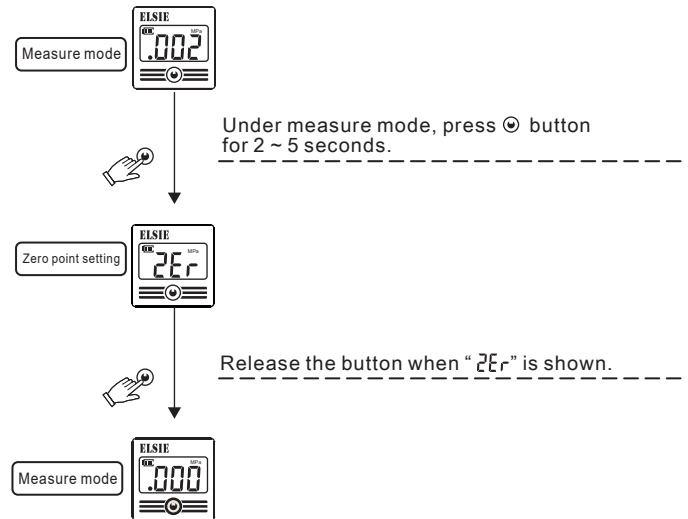

K. DUST AND SPLASH ENVIRONMENT

- To maintain IP65, please insert an air tube (O.D.: 4mm) into atmospheric release port and pipe the other end away from dust / splattering liquid environment.
- Use proper air tube dimension of O.D.: 4mm, I.D.: 2.5mm, and the length is depending on the user's environment.

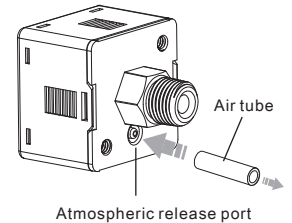

L. ERROR CODE INSTRUCTION

Error Type	Error code	Error Condition	Troubleshooting
Residual pressure error	Err	During zero reset, ambient pressure is over ±3% F.S.	Change input pressure to ambient pressure and perform zero reset again.
Applied pressure error	HHH	Supply pressure is exceeds the upper limit of pressure setting.	Adjust the pressure within operating pressure range.
	LLL	Supply pressure is exceeds the lower limit of pressure setting.	
Battery error	bAt	When battery level is under 2.40V, the battery symbol and bAt will flash 4 times then enter power save mode.	Replace battery.